

# 23245

*by* Andi Andi

---

**Submission date:** 09-Oct-2023 08:55PM (UTC+0700)

**Submission ID:** 2179253559

**File name:** 23245-67249-1-CE.docx (498.34K)

**Word count:** 3751

**Character count:** 19801

# PLANNING STUDY OF HYBRID POWER PLANT PV-DIESEL ON KODINGARE ISLAND, SINJAI REGENCY

M.Y.Yunus<sup>1\*</sup>, Lewi<sup>2</sup>, A.S.Rijal<sup>3</sup>, N.Huda<sup>4</sup>, A.Ikram<sup>5</sup>

15

Department of Mechanical Engineering, Ujung Pandang State Polytechnic, Makassar 90245, Indonesia

## Abstract

Kodingare Island is located in Pulau Sembilan District, Sinjai Regency, and is one of nine islands in the district. Currently, the majority of people still rely on conventional energy from diesel power plants. The reason is, this island does not yet receive electricity supply from the electricity grid due to the geographical limitations of the archipelago. It is known that the most potential renewable energy source on Kodingare Island is solar energy with a potential for solar radiation reaching 5.86 kWh/m<sup>2</sup>/day. This research aims to analyze an innovation that combines PV and solar, where PV acts as the main electricity generator, while solar functions as a backup and additional energy source. The method used in this research uses simulation methods, layout modeling and financial analysis using HOMER Pro simulation software to determine the potential and performance of hybrid power plants and using SketchUp Pro software to produce three-dimensional layouts as well as economic and feasibility values obtained through financial analysis. Technical aspects include the production of an electrical energy system of 37,029 Wh/year, consisting of PV of 32,981 Wh/year and solar of 4,048 Wh/year with energy consumption of 33,850 Wh/year. The required fuel consumption is 2,086 L/year, with excess electricity of 931 kWh/year, and renewable energy penetration of 89.1%. From an economic aspect, planning this hybrid power system requires an investment of 258.290.000 IDR, O&M costs of 19.350.600 IDR and the Cost of Energy value is 1,352/kWh IDR, while from the feasibility aspect of planning a hybrid electric power system it is said to be feasible because it produces a Net Present Value of 9,870,151 IDR is greater than zero, the Profitability Index is 1.03 greater than one, the Internal Rate of Return is 8.90% greater than the credit interest rate of 8.43% and the Payback Period required for return of capital is 9 years 9 months.

**Keywords:** hybrid power system, HOMER Pro, pv, diesel

\*Corresponding author: Telp. +6282346999002

E-mail address: [yunus\\_it@yahoo.com](mailto:yunus_it@yahoo.com)

## 1. Introduction

Indonesia, as the largest country in the world, consisting of around 17,500 islands with a population of around 220 million people, has significant challenges in meeting its electrical energy needs [1]. Currently, most electricity sources in Indonesia still depend on fossil fuels, with more than 82% of electricity produced from this source, while 18% comes from renewable energy. Even though the potential for solar energy in Indonesia reaches 207,898 MW, its utilization is still very low, around 0.04% [2]. In the midst of this context, Kodingare Island faces the problem of electrical energy supply provided by diesel which can only operate for seven hours. Before being supplied with diesel, Kodingare Island had a solar power plant with a capacity of 11.72 kWp [3]. This PLTS can only operate for less than a year due to high voltage caused by lightning and lack of adequate maintenance.

Research evaluating the optimal solar panel and battery configuration for a 4 kW power plant in Lubumbashi, DR Congo, found that the PV system

was able to produce an energy surplus of 38% [4]. The system is designed with PV-Diesel with 70% Renewable Penetration and 18 hours of autonomy as a more economical alternative to increase electrification in Indonesia with lower investment costs [5]. Research that highlights the management of redundant energy in PV-Battery-Diesel systems in Palestine, resulting in efficient reduction of electricity costs [6] as well as research that explores the application of renewable energy to replace diesel generators on remote islands of the Indian Ocean, with the result that renewable energy contributes by 29.2%, reducing electricity costs and demonstrating the feasibility of the technology for areas that do not yet have access to electricity in Indonesia [7].

Therefore, this research will focus on modeling and simulation using HOMER Pro software to evaluate the potential and performance of the hybrid power system on Kodingare Island [8]. Apart from that, economic aspects and planning feasibility will also be important aspects in optimizing this system. Thus, this research aims to produce a design that

includes technical, economic and feasibility aspects to overcome energy challenges on Kodingare Island by considering several advantages that were not available in previous research, such as three-dimensional PV layout planning and higher renewable penetration contribution. .

## 2. Experimental and Procedures

### 2.1 Economic Analysis

#### a. Initial Investment

The initial investment costs for a hybrid power system on Kodingare Island include costs such as: general costs for all components, mechanical and electrical work costs [9].

#### b. Maintenance and Operational Costs (O&M)

Operating costs include day-to-day expenses such as fuel and labor. Meanwhile, maintenance costs include expenses to maintain optimal condition and performance through inspection, repair and replacement of worn or damaged components, calculated using the following equation [10]:

$$M = 1\%/2\% \times \text{total initial investment costs} \quad (1)$$

where:

M = cost O&M (IDR).

#### c. Life Cycle Cost (LCC)

The concept of calculating total costs from start to maintenance of the project. This includes all costs such as initial investment, operations, maintenance, and replacement, calculated using the following equation [11]:

$$AW = A \left[ \frac{(1+i)^n - 1}{i(1+i)^n} \right] \quad (2)$$

LCC using the following equation [11]:

$$LCC = Ct + AW \quad (3)$$

where:

LCC = life cycle cost (IDR)

Ct = initial investment + component replacement costs (IDR)

AW = present value costs for total maintenance and operational costs for n years of project life (IDR)

i = interest rate (%)

#### d. Cost of Energy (COE)

Total energy costs are determined by LCC, capital recovery factor and total annual energy load, calculated using the following equation [11]:

$$CRF = \frac{i(1+i)^n}{(1+i)^n - 1} \quad (4)$$

COE for PV are calculated using the following equation [11]:

$$COE = \frac{LCC \times CRF}{A \text{ kWh}} \quad (5)$$

where:

COE = cost of energy (IDR)

CRF = capital recovery factor

LCC = life cycle cost (IDR)

A kWh = total annual energy load (kWh/year)

i = interest rate (%)

### 2.2 Feasibility Analysis

#### a. Payback Period (PBP)

The time required for the investment that has been issued to be returned to investors. The smaller the PBP value, the better, the risk factor for the return on capital will be faster in a short time, calculated using the following equation [12]:

$$PBP = \frac{\text{Initial Investment}}{\text{Total Net Cash}} \quad (6)$$

#### b. Net Present Value (NPV)

A comparison between the market value of an investment and the cost itself. If the NPV value is negative, then the project is not recommended for implementation, if the value is positive, then the project is feasible to implement. The NPV value is zero, meaning there is no difference if the project is still implemented or rejected, calculated using the following equation [13]:

$$DF = \frac{1}{(1+i)^t} \quad (7)$$

$$NPV = \sum_{t=1}^n \frac{NCF_t}{(1+i)^t} - II \quad (8)$$

where:

NCFt = Net Cash Flow for the period from year 1 to year n (IDR)

n = investment age (year)

II = cost initial investment (IDR)

i = interest rate (%)

#### c. Profitability Index (PI)

Showing the profits obtained from a project within the life of the project, investment can be said to be feasible if PI must be greater than 1, because 1 is the break-even point between the investment value and profits, calculated using the following equation [10]:

$$PI = \sum_{t=1}^n \frac{NCF_t(1+i)^{-t}}{I} \quad (9)$$

where:

NCF<sub>t</sub> = Net Cash Flow for the period from year 1 to year n (IDR)

n = investment age (year)

I = cost initial investment (IDR)

i = interest rate (%)

20

#### d. Internal Rate of Return (IRR)

The discount rate that makes the present value of all expected revenues equal the present value of all costs involved in the project. The higher the IRR value, the more profitable the project is, and projects that have an IRR greater than the discount rate used are considered feasible to run, calculated using the following equation [13]:

$$IRR = ir + \left( \frac{NPVr}{NPVr - NPVt} \right) (it - ir) \quad (10)$$

dimana:

NPV<sub>r</sub> = Net Present Value with low interest rates (IDR)

NPV<sub>t</sub> = Net Present Value with high interest rates (IDR)

ir = low interest rates (%)

it = high interest rates (%)

### 2.3 Research Stages

The research begins with selecting a research area based on the problems studied in the introduction. The next process is to carry out a simulation using HOMER software to produce technical aspects in the form of energy production to compare the power contribution of each diesel, fuel consumption, excess electricity and renewable energy penetration.

Economic and feasibility aspects are carried out using numerical calculations with financial analysis methods with input from HOMER software output. Economic aspects include initial investment costs, O&M costs, LCC, and COE. However, to get these results, researchers must first determine the investment costs for designing the hybrid power plant.

The feasibility aspect of this research is the design performance evaluation aspect. Several standards in this planning are based on the economic price per kWh, [17] with a period shorter than the useful life, positive NPV, IRR greater than the credit interest rate, and PI greater than one, where the final stage of this research is designing the layout placement using SketchUp Pro software.

## 3. Results and Discussion

### 3.1 Electrical Energy Load Profile

The first step in this design is to determine the total daily load used. The daily load on Kodingare Island is the electrical energy consumption load consisting of Household loads, Mushalla, Schools, Pustu, and Public toilets can be seen in Table 1 below.

Table 1. Estimated Electricity Demand of Kodingare Island for 24 Hours

Building Type	Qty	Equipment Name	Qty	Power (W)	Total Power (kW)	Time (h)	Energy Consumption (kWh)
Household	120	Lamp	4	10	4.800	8	38.400
		TV	1	70	8.400	3	25.200
		Fan	1	40	4.800	4	19.200
		Electrical Device	1	14	1.680	4	6.720
Mushalla	1	Lamp	4	10	40	5	200
		Amplifier	1	30	30	1	30
		Fan	4	45	180	4	720
		Loadspeaker	1	50	50	1	50
School	1	Lamp	4	10	40	5	200
		Fan	3	20	80	5	400
Subtite Health Center	1	Lamp	2	10	20	5	100
		Fan	2	20	40	5	200
		Electrical Device	1	20	20	5	100
Public Restroom	7	Lamp	1	10	70	5	350
Total					20.160		91.870

### 3.2 Technical Analysis of HOMER Pro Software Simulation

#### a. Total Electrical Energy Generated

The total energy generated from the Hybrid Power Plant system can be seen in Figure 1 below.

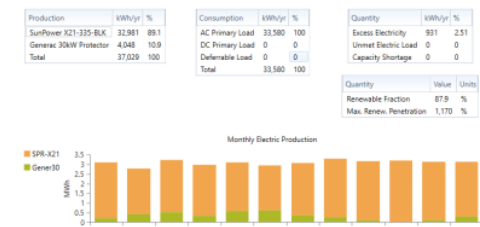

Fig. 1. Display of Total Electric Energy Production

It can be seen that AC load consumption is 33,580 kWh/year, where electricity production from solar panels reaches 32,981 Wh/year or 89.1%, solar is 4,048 Wh/year or 10.9% of total production and excess electricity is 931 kWh/year and the renewable fraction was 87.9% greater than previous research [5].

**b. Fuel Consumption**

Figure 2 shows data in the form of the amount of fuel consumption used in supplying electrical power to the load of 5.71 L/day and 2,086 L/year with the energy generated of 4,048 Wh/year. The detailed data obtained regarding fuel consumption can be seen in Figure 2 below.

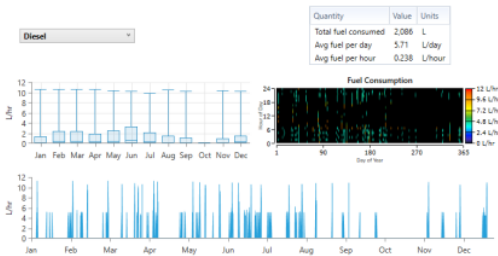

Fig. 2. Fuel Consumption

**3.3 Hybrid Power Plant System Design**

This hybrid power generation system uses 3 sets of solar panels, each arranged in 4 series and 3 parallel, where each set of panels has a capacity of 5,640 Wp which is connected to an inverter, each with a capacity of 8 kW. This Hybrid Power Generation System uses 48 batteries arranged in series, 24 with 2 in parallel, and uses 1 diesel power with a capacity of 30 kW. Equipped with a DC and AC protection system and an ATS as a switch from the generating source. The wiring diagram for this Hybrid Power Plant system can be seen in Figure 3 below.

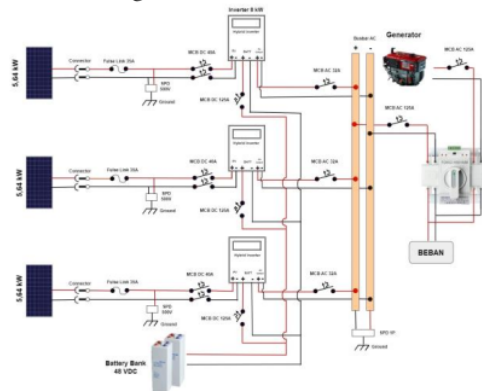

Fig. 3. Hybrid Power Plant System Wiring

**3.4 Economic Analysis**

**a. Initial Investment Cost**

All costs incurred for the construction of the Hybrid Power Plant system as shown in table 2 below.

Table. 2. Initial Investment

No	Component	Qty	Unit Price (IDR)	Subtotal (IDR)
<b>Main Component</b>				
1	Diesel 30 kW	1	-	Available
2	Solar Panel 470 Wp	36	2.800.000	100.800.000
	Inverter 8 kW	3	10.500.000	31.500.000
4	Battery 2V 1500 Ah	39	-	Available
5	Battery 2V 1500 Ah	9	6.650.000	59.850.000
<b>Total Price A</b>				<b>192.150.000</b>
<b>DC Side Protection Device</b>				
1	Panel Box	2	238.000	476.000
2	NT Fuse 35A	3	25.000	75.000
3	MCB DC 40A	3	56.000	168.000
4	MCB DC 125A	3	215.000	645.000
5	Arrester SPD 500V	3	145.000	435.000
<b>Total Price B</b>				<b>1.799.000</b>
<b>AC Protection Device</b>				
1	Panel Box	1	335.000	335.000
2	MCB AC 125A	2	215.000	430.000
3	MCB AC 32A	3	118.000	354.000
4	Arrester AC SPD 1P	1	140.000	140.000
<b>Total Price C</b>				<b>1.259.000</b>
<b>Cable</b>				
1	NYAF 1x10 mm	15	22.000	330.000
2	NYAF 1x16 mm	1	1.600.000	1.600.000
3	NYHY 2x25 mm	10	1.800.000	18.000.000
4	NYAF 50 mm	20	100.000	2.000.000
5	NYA 50 mm	30	90.000	2.700.000
<b>Total Harga D</b>				<b>26.830.000</b>
<b>Other Components</b>				
1	PV Support	1	-	Available
2	Distribution Pole	10	-	Available
3	Lighting Rod	1	-	Available
4	Konektor MC4	10	40.000	400.000
5	ATS	1	450.000	450.000
6	Copper Busbar	5	50.000	250.000
7	Din Rail	6	17.000	102.000
8	PVC AW 1/2 Inchi	50	10.000	500.000
9	Grounding 1.5 m	4	55.000	220.000
10	Terminal Block TB	2	10.000	20.000
11	Cable Clips 10 mm	50	4.000	200.000
13	Tiger Nail Clamps	5	22.000	110.000
14	Installation Service	17	2.000.000	34.000.000
<b>Total Price E</b>				<b>36.252.000</b>
<b>Initial Investment</b>				<b>258.290.000</b>

**b. Operational and Maintenance Cost**

The total costs incurred for O&M costs of hybrid power plant include the purchase of generating fuel costs, and a cost of 2% of the total initial investment costs, where the calculation of O&M costs can be seen as follows:

Operational costs can be calculated based on fuel consumption worth 6.800/Liter IDR [14] and fuel consumption of 2.086 Liters with the following calculations:

$$\begin{aligned} \text{Operational Cost} &= 2.086 \times 6.800 \\ &= 14.184.800 \text{ IDR} \end{aligned}$$

Hybrid power plant maintenance costs per year are calculated with the following equation:

$$\begin{aligned} \text{Maintenance Cost} &= 2\% \times \text{Initial Investment} \\ &= 2\% \times 258.290.000 \\ &= 5.165.800 \text{ IDR} \end{aligned}$$



With a total O&M cost of 19.350.600 IDR.

c. *Lyfe Cycle Cost*

The plan is that this Hybrid Power Plant can operate for 25 years based on the age of the solar panels. The interest rate used is 8.43% [15] and the operating cost is 14.184.800 IDR which can be calculated using the following equation:

$$AW = A \times \left[ \frac{(1+i)^n - 1}{i(1+i)^n} \right]$$

$$AW = 14.184.800 \times \left[ \frac{(1+0.0843)^{25} - 1}{0.0843(1+0.0843)^{25}} \right]$$

$$= 14.184.800 \times 10.28$$

$$= 145.819,744 \text{ IDR}$$

From the fixed cost of maintenance over a 25-year period, the LCC can be determined as follows:

$$LCC = Ct + AW$$

$$= (258,290,000 + 63,000,000) + 145,819,744$$

$$= 467,109,744 \text{ IDR}$$

Based on the above calculations, the life cycle cost of Hybrid Power Plant is 467.109.744 IDR.

d. *Cost of Energy*

The Capital Recovery Factor (CRF) to convert all life cycle cash flows into a series of annualized costs is calculated using the following equation:

$$CRF = \frac{i(1+i)^n}{(1+i)^n - 1}$$

$$= \frac{0.0843(1+0.0843)^{25}}{(1+0.0843)^{25} - 1}$$

$$= \frac{0.638}{6.564}$$

$$= 0.0972$$

Based on the calculation of LCC, CRF and total annual energy for a load of 33,580 Wh, it is possible to determine the COE, with the following calculation:

$$COE = \frac{LCC \times CRF}{A \text{ KWH}}$$

$$= \frac{467,109,744 \times 0.0972}{33,580}$$

$$= 1,352/\text{kWh IDR}$$

The COE value obtained is lower than the electricity price in the previous research system design [5][6][7].

3.5 *Feasibility Analysis*

a. *Payback Period*

Calculation of energy cost as energy:

$$\text{Cash Inflow} = \text{Total Energy Consumption} \times \text{Selling Price of Electricity}$$

$$= 33.580 \text{ Wh/year} \times 1.352$$

$$= 45.400.160/\text{year IDR}$$

$$\text{Cash Outflow} = \text{PV Maintenance} + \text{Op.Diesel}$$

$$= 5.165,800 + 14.184.400$$

$$= 19.350.200/\text{year IDR}$$

$$\text{Net Income} = \text{Cash Inflow} - \text{Total Expenses}$$

$$= 45.400.160 - 19.350.200$$

$$= 26.049.960/\text{year IDR}$$

Based on the calculation of LCC, CRF and annual kWh above, the COE value is obtained with the following calculation:

$$\text{Payback Period} = \frac{\text{Modal Investasi Awal}}{\text{Pendapatan}}$$

$$= \frac{258,290,000}{26,049,960}$$

$$= 9 \text{ Years } 9 \text{ Months}$$

b. *Net Present Value*

The NPV value is calculated by looking at the total net income to get the NPV value of a system, then the future value total net income is compared to the value of the present value of the system or the initial investment of the plant. The NPV value can be obtained based on the following equation

Table. 3. *Net Present Value*

NET PRESENT VALUE				
Year	Initial Investment (IDR)	NCF (IDR)	DF	PVNCF (IDR)
0	258.290.000		1	258.290.00
1		26.049.960	0,922	24.024.680
2		26.049.960	0,851	22.156.857
3		26.049.960	0,784	20.434.249
4		26.049.960	0,723	18.845.568
5		26.049.960	0,667	17.380.400
6		26.049.960	0,615	16.029.143
7		26.049.960	0,567	14.782.941
8		26.049.960	0,523	13.633.627
9		26.049.960	0,483	12.573.667
10		26.049.960	0,445	11.596.114
11		26.049.960	0,411	10.694.563
12		26.049.960	0,379	9.863.103
13		26.049.960	0,349	9.096.286
14		26.049.960	0,322	8.389.086
15		26.049.960	0,297	7.736.868
16		26.049.960	0,274	7.135.357
17		26.049.960	0,253	6.580.612
18		26.049.960	0,233	6.068.996
19		26.049.960	0,215	5.597.155
20		26.049.960	0,198	5.161.999
21		26.049.960	0,183	4.760.674
22		26.049.960	0,169	4.390.551
23		26.049.960	0,155	4.049.203
24		26.049.960	0,143	3.734.393
25		26.049.960	0,132	3.444.059
<b>TOTAL</b>				268.160.151
<b>DISKONTO ANNUITIES</b>				10,29



Table 3 shows that the total present value of the net cash flow as a result of multiplying the net cash flow by the discount factor is 268.160.151 IDR, if the initial investment is 258,290,000 IDR, then the NPV can be calculated as follows:

$$\begin{aligned} NPV &= \sum_{t=1}^n \frac{NCF_t}{(1+i)^t} - II \\ &= 268.160.151 - 258.290.000 \\ &= 9.870.151 \text{ IDR} \end{aligned}$$

### c. Internal Rate of Return

To determine the IRR value when NPV = 0, the interpolation method is used between interest rates that produce positive NPV and interest rates that produce negative NPV where the low interest rate used is 7% and the high interest rate is 9%. The NPV value with a low interest rate can be obtained based on the following equation:

Table 4. Interest Rate 7% and Interest Rate 9%

NET PRESENT VALUE					
Year	NCF (IDR)	DF (7%)	PVNCf (IDR)	DF (9%)	PVNCf (IDR)
0		1	258.290.00	1	258.290.00
1	26.049.960	0,935	24.345.757	0,917	23.899.046
2	26.049.960	0,873	22.753.044	0,842	21.925.730
3	26.049.960	0,816	21.264.527	0,772	20.115.349
4	26.049.960	0,763	19.873.390	0,708	18.454.448
5	26.049.960	0,713	18.573.261	0,650	16.930.687
6	26.049.960	0,666	17.358.188	0,596	15.532.740
7	26.049.960	0,623	16.222.606	0,547	14.250.220
8	26.049.960	0,582	15.161.314	0,502	13.073.597
9	26.049.960	0,544	14.169.452	0,460	11.994.125
10	26.049.960	0,508	13.242.479	0,422	11.003.785
11	26.049.960	0,475	12.376.148	0,388	10.095.215
12	26.049.960	0,444	11.566.494	0,356	9.261.665
13	26.049.960	0,415	10.809.807	0,326	8.496.941
14	26.049.960	0,388	10.102.624	0,299	7.795.358
15	26.049.960	0,362	9.441.704	0,275	7.151.705
16	26.049.960	0,339	8.824.023	0,252	6.561.197
17	26.049.960	0,317	8.246.750	0,231	6.019.447
18	26.049.960	0,296	7.707.243	0,212	5.522.428
19	26.049.960	0,277	7.203.031	0,194	5.066.448
20	26.049.960	0,258	6.731.805	0,178	4.648.118
21	26.049.960	0,242	6.291.406	0,164	4.264.328
22	26.049.960	0,226	5.879.819	0,150	3.912.228
23	26.049.960	0,211	5.495.158	0,138	3.589.200
24	26.049.960	0,197	5.135.662	0,126	3.292.844
25	26.049.960	0,184	4.799.684	0,116	3.020.957
<b>TOTAL</b>			303.575.376		255.877.806
<b>NPV</b>			45.285.376	<b>NPV</b>	-2.412.194
<b>DISKONTO ANNUITIES</b>			11,65		9,82

From the table above, the data as shown in Table 4 below is then calculated using the following equation:

$$\begin{aligned} IRR &= Ir + \left( \frac{NPV_r}{NPV_r - NPV_t} \right) (It - Ir) \\ &= 7\% + \left( \frac{45.285.376}{45.285.376 - (-2.412.194)} \right) (9\% - 7\%) \\ &= 8,90\% \end{aligned}$$

Obtaining an IRR value of 8.90%, higher than the credit interest rate of 8.43%, which is why the Hybrid Power Plant plan is considered feasible on Kodingare Island.

### d. Profitability Index

With a total net cash flow present value of 268.160.151 IDR and an initial investment cost of 258,290,000 IDR, the PI value can be calculated as follows:

$$\begin{aligned} \text{Profitability Index} &= \sum_{t=1}^n \frac{NCF_t(1+i)^{-t}}{II} \\ &= \frac{268.160.151}{258.290.000} \\ &= 1.03 \end{aligned}$$

The results of the PI calculation which has a value of 1.03 > 1 indicate that the Hybrid Power Plant investment on Kodingare Island to be planned is feasible.

### 3.6 Layout in 3D

This project was carried out by redrawing the layout of the placement of solar panels, inverters, batteries, and various other components using SketchUp Pro software. The final design can be seen in the image below:

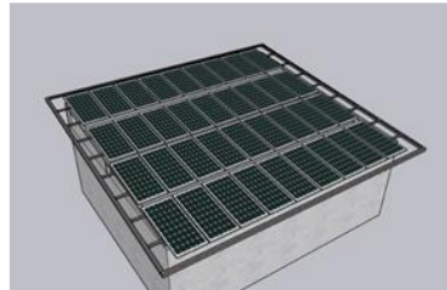

Fig. 4. Top View of Layout



Fig. 6. Inside View Layout

#### 4. Conclusions

Based on the design results, it is designed to produce electrical energy of 37,029 Wh/year, energy consumption of 33,850 Wh/year. With excess electricity of 931 kwh/year. From an economic aspect, this system requires an investment of 258.290.000 IDR, O&M costs of 19.350.600 IDR and the cost of energy value is 1.352/kwh IDR while from the feasibility aspect, this system is said to be feasible because it produces a net present value greater than zero, a profitability index greater than one, an internal rate of return greater than the credit interest rate and the payback period required to return capital is 9 years 9 months.

#### 5. Acknowledgements

A thankful statement is addressed to the Departement of Mechanical Engineering, Ujung Pandang State Polytechnic, Makassar, Indonesia, for valuable support.

#### References

- [1] Djamin, M. (2010). *Penelitian Penerapan Pembangkit Listrik Tenaga Surya Dan Dampaknya Terhadap Lingkungan*. 11(2), 221–225.
- [2] Persero, P. P. (2018). *Rencana usaha penyediaan tenaga listrik (ruptl) pt pln (persero)*. <https://web.pln.co.id/static/uploads/2021/10/ruptl-2021-2030>
- [3] Usman, & Muhammad, U. (2016). *Perencanaan dan Analisis Ekonomi PLTS Terpusat (Studi Kasus: Pulau Kodingare)*.
- [4] Rice, I. K., Zhu, H., Zhang, C., & Tapa, A. R. (2023). A Hybrid Photovoltaic / Diesel System for Off-Grid Applications in Lubumbashi , DR Congo : A HOMER Pro Modeling and Optimization Study. *Sustainability* 2023, 15, 62. <https://doi.org/10.3390/su15108162>.
- [5] Wicaksana, H. I., Muslim, M. M., Hutapea, S. F., Purwadi, A., & Haroen, Y. (2016). *Design , Implementation and Techno-Economic Analysis of Hybrid PV-Diesel for Off-Grid System in Iriara Island*. 39–44.
- [6] Yasin, A., & Alsayed, M. (2020). Optimization with excess electricity management of a PV , energy storage and diesel generator hybrid system using HOMER Pro software. *Applied Power Engineering*, 9(3), 267–283. <https://doi.org/10.11591/ijape.v9.i3.pp267-283>
- [7] Riayatsyah, T. M., Geumpana, T. A., & Fattah, I. M. R. (2022). Techno-Economic Analysis of Hybrid Diesel Generators and Renewable Energy for a Remote Island in the Indian Ocean Using HOMER Pro. *Sustainability* 2022, 14, 9846. <https://doi.org/10.3390/su14169846>.
- [8] Navies, A. (2021). *Analisis Teknis Dan Ekonomi Pembangkit Listrik Tenaga Hybrid Biomass-Biogas (Studi Kasus: PT.Perkebunan Nusantara V Sei Galuh)*.
- [9] Bagaskoro, B., & Windarta, J. (2019). *Listrik Tenaga Surya Sistem Offgrid Menggunakan Cemara*. 8(2), 152–157.
- [10] Chandra, Y. (2016). *Analisis Ekonomi Energi Perencanaan Pembangunan PLTS ( Studi Kasus Gedung Kuliah Politeknik Negeri Ketapang )*. 8(1), 25–31.
- [11] Sitohang, M. P. (2019). Tugas akhir. *In Perancangan Pembangkit Listrik Tenaga Surya (PLTS) Terpusat Off-Grid System*.
- [12] Hajir, N. (2021). *Analisa Perencanaan Pembangkit Listrik Tenaga Surya Atap Dengan Sistem Hybrid Di Pt Koloni Timur*.
- [13] Yonata, K. (2017). *Analisis Tekno-Ekonomi Terhadap Desain Sistem Plts Pada Bangunan Komersial Di Surabaya , Indonesia*.
- [14] Nasution, D. D. (2023). *Harga BBM di SPBU Pertamina Naik Lagi per 1 Agustus 2023*. Republika. <https://ekonomi.republika.co.id/berita/ryp0qi490/duh-harga-bbm-di-spbu-pertamina-naik-lagi-per-1-agustus-2023>
- [15] Indonesia, B. (2023). *Suku Bunga Bank Indonesia*. [www.bi.go.id/](http://www.bi.go.id/).

## ORIGINALITY REPORT

13%

SIMILARITY INDEX

13%

INTERNET SOURCES

11%

PUBLICATIONS

7%

STUDENT PAPERS

## PRIMARY SOURCES

1	Eko Wahyono, Reza Amarta Prayoga, Fatwa Nurul Hakim, Nuzul Solekha et al. "Economic Mitigation Institutions: A New Approach to Livelihood Systems in Disaster-Prone Areas", Society, 2023 Publication	2%
2	Submitted to STKIP Sumatera Barat Student Paper	1%
3	www.mdpi.com Internet Source	1%
4	Submitted to Bridgepoint Education Student Paper	1%
5	opus.lib.uts.edu.au Internet Source	1%
6	www.igi-global.com Internet Source	1%
7	archive.epa.gov Internet Source	1%
8	Submitted to Edith Cowan University Student Paper	

		1 %
9	<a href="http://ejournal.unkhair.ac.id">ejournal.unkhair.ac.id</a> Internet Source	1 %
10	<a href="http://journal.portalgaruda.org">journal.portalgaruda.org</a> Internet Source	1 %
11	<a href="http://openjournal.unpam.ac.id">openjournal.unpam.ac.id</a> Internet Source	1 %
12	<a href="http://penerbit.brin.go.id">penerbit.brin.go.id</a> Internet Source	<1 %
13	<a href="http://www.grafiati.com">www.grafiati.com</a> Internet Source	<1 %
14	Rendy A. Rachmanto, Farel J. Regannanta, Ubaidillah, Zainal Arifin, Denny Widhiyanuriyawan, Eflita Yohana, Singgih D. Prasetyo. "Analysis Development of Public Electric Vehicle Charging Stations Using On-Grid Solar Power Plants in Indonesia", International Journal of Transport Development and Integration, 2023 Publication	<1 %
15	<a href="http://repository.poliupg.ac.id">repository.poliupg.ac.id</a> Internet Source	<1 %
16	Siti Aisyah Tri Rahayu, Mulyanto Mulyanto, Johadi Johadi, Muhammad Yusuf Indra	<1 %

# Purnama. "The Nexus of Risk-Preferences and Poverty in Indonesia", Society, 2023

Publication

---

17	<a href="http://ia801504.us.archive.org">ia801504.us.archive.org</a> Internet Source	<1 %
18	<a href="http://seminar-fst.uin-suska.ac.id">seminar-fst.uin-suska.ac.id</a> Internet Source	<1 %
19	<a href="http://ijape.iaescore.com">ijape.iaescore.com</a> Internet Source	<1 %
20	<a href="http://nanopdf.com">nanopdf.com</a> Internet Source	<1 %

---

Exclude quotes  Off

Exclude matches  < 17 words

Exclude bibliography  Off

---

PAGE 1

---

PAGE 2

---

PAGE 3

---

PAGE 4

---

PAGE 5

---

PAGE 6

---

PAGE 7

---