

# Program Profesi Insinyur FT

## 27939-80890-1-RV (damar) (Layout) Rev MF.edited

 GENAP 2024/2025 (42)

---

### Document Details

Submission ID

trn:oid::3618:126952199

Submission Date

Jan 27, 2026, 11:52 AM GMT+7

Download Date

Jan 27, 2026, 1:38 PM GMT+7

File Name

27939-80890-1-RV (damar) (Layout) Rev MF.edited.docx

File Size

767.3 KB

9 Pages

2,991 Words

15,489 Characters

# 24% Overall Similarity

The combined total of all matches, including overlapping sources, for each database.

## Filtered from the Report

- ▶ Bibliography
- ▶ Quoted Text

## Exclusions

- ▶ 21 Excluded Sources

## Match Groups

- 59 Not Cited or Quoted 21%**  
Matches with neither in-text citation nor quotation marks
- 5 Missing Quotations 3%**  
Matches that are still very similar to source material
- 0 Missing Citation 0%**  
Matches that have quotation marks, but no in-text citation
- 0 Cited and Quoted 0%**  
Matches with in-text citation present, but no quotation marks

## Top Sources

- 18% Internet sources
- 15% Publications
- 15% Submitted works (Student Papers)

## Integrity Flags

0 Integrity Flags for Review

Our system's algorithms look deeply at a document for any inconsistencies that would set it apart from a normal submission. If we notice something strange, we flag it for you to review.

A Flag is not necessarily an indicator of a problem. However, we'd recommend you focus your attention there for further review.

### Match Groups

- **59 Not Cited or Quoted 21%**  
Matches with neither in-text citation nor quotation marks
- **5 Missing Quotations 3%**  
Matches that are still very similar to source material
- **0 Missing Citation 0%**  
Matches that have quotation marks, but no in-text citation
- **0 Cited and Quoted 0%**  
Matches with in-text citation present, but no quotation marks

### Top Sources

- 18% Internet sources
- 15% Publications
- 15% Submitted works (Student Papers)

### Top Sources

The sources with the highest number of matches within the submission. Overlapping sources will not be displayed.

1	Internet	<b>jurnal.sttmicileungsi.ac.id</b>	4%
2	Internet	<b>semarakilmu.com.my</b>	2%
3	Internet	<b>ojs.uma.ac.id</b>	2%
4	Internet	<b>www.researchgate.net</b>	1%
5	Internet	<b>eudl.eu</b>	1%
6	Publication	<b>Rongyuan Jia, Huajjie Xia, Song Zhang, Weiguang Su, Shuhui Xu. "Optimal design ...</b>	1%
7	Publication	<b>Wiwit Suprihatiningsih, Abdul Hamid, Adji Nur Fadilah. "Performance analysis of...</b>	<1%
8	Student papers	<b>Nottingham Trent University on 2024-12-31</b>	<1%
9	Internet	<b>ijpeds.iaescore.com</b>	<1%
10	Publication	<b>Abdul Rahim, Wan Khairul Muzammil. "Design and Testing of a Deflector Integrat...</b>	<1%

11	Student papers	Academic Library Consortium on 2018-01-16	<1%
12	Student papers	RMIT University on 2025-11-17	<1%
13	Student papers	University of Bradford on 2024-11-22	<1%
14	Internet	sustainablenessu.sonoma.edu	<1%
15	Internet	www.mdpi.com	<1%
16	Internet	ejournal2.undip.ac.id	<1%
17	Student papers	Khulna University of Engineering & Technology on 2025-09-22	<1%
18	Student papers	Sheffield Hallam University on 2018-04-12	<1%
19	Student papers	University of Limerick on 2012-03-20	<1%
20	Internet	erydgjj.farmaciasantostefano.it	<1%
21	Internet	sil0.tips	<1%
22	Internet	www.frontiersin.org	<1%
23	Internet	www.ijesd.org	<1%
24	Student papers	Oregon State University on 2025-02-03	<1%

25	Internet	acikerisim.karabuk.edu.tr:8080	<1%
26	Internet	jurnal.polines.ac.id	<1%
27	Publication	Bhati, Mohammad Uzair. "Micro Wind Turbine - Modelling and Testing", Clemson ...	<1%
28	Publication	Denny Irawan, Zizin Anggun Kinanti. "Performance Analysis of Wind Turbine", Ko...	<1%
29	Student papers	Universitas Muria Kudus on 2018-09-04	<1%
30	Internet	asmedigitalcollection.asme.org	<1%
31	Internet	repository.uai.ac.id	<1%
32	Internet	ubir.buffalo.edu	<1%
33	Publication	Qiang Gao, Nesimi Ertuğrul. "Techno-Economics of Offshore Renewable Energy - ...	<1%
34	Student papers	Bolton Institute of Higher Education on 2013-05-12	<1%
35	Publication	Hashem Abusannuga. "Verification of the self-starting problem of a Vertical Axis ...	<1%
36	Publication	S W Wasiati, F A Augusta, V R P Purwanto, P Wulandari, A Syahrir. "Darrieus typ...	<1%

# FIELD TEST STUDY ON WIND TURBINE PERFORMANCE HORIZONTAL AXIS THREE SPIRAL BLADES RELATED TO SOLIDITY NUMBER EFFECTS

Yudi Wantoso<sup>1</sup>, Abdul Hamid<sup>1</sup>

<sup>1</sup>Mechanical Engineering Departement, Faculty of Engineering, Mercu Buana University Jakarta, 11650, Indonesia

E-mail: [41318120013@student.mercubuana.ac.id](mailto:41318120013@student.mercubuana.ac.id)

**Abstract**--The use of electrical energy in Indonesia is currently very high. However, the energy used is still dominated by fossil energy, even though the potential for alternative energy in Indonesia is huge and cannot be utilised properly, one of which is wind energy. Wind power plants are renewable energy plants where the use of renewable energy is expected to replace energy sourced from fossil fuels, which are limited in Number. This research was conducted using a three-blade spiral horizontal axis wind turbine (TASH) to investigate the effect of solidity number on the performance of TASH with a diameter of 1.536 m. The method used in this study is a field test conducted at Tanjung Pasir beach, Tangerang Regency, Banten. TASH performance is assessed by measured parameters such as voltage value, generator output current, and torque value; also, non-dimensional parameters such as power coefficient, torque coefficient,  $C_T$ , and the value of Tip Speed Ratio, TSR, generated due to TASH rotation at each wind speed from 1 m/s to 6 m/s. Field test results obtained. Experimental actual power = 9.991 watts, torque value = 6.0 Nm (wind speed 5 m/s), Power coefficient,  $C_P = 0.066$  and Torque coefficient,  $C_T = 0.674$  at 2.0 m/s wind speed, Solidity number = 0.976

## Article History:

Received: Juny 24, 2024

Revised: January 22, 2025

Accepted: October 02, 2025

Published: xxxx, xxxx

**Keywords:** TASH Spiral Blade, Solidity Number, Power Coefficient,  $C_P$ ; Torque Coefficient,  $C_T$ ; and Tip Speed Ratio, TSR.

This is an open access article under the [CC BY-SA](https://creativecommons.org/licenses/by-sa/4.0/) license



## 1. INTRODUCTION (Arial 10pt; Bold)

The availability of electrical energy in the national energy supply system is crucial and plays a vital role in maintaining the country's economic continuity. Especially when fossil fuels are still scarce, this highlights the challenges that countries face in meeting their energy needs, population growth, and economic development. In the national energy policy, one of the central guidelines for national energy development is to strengthen energy from renewable energy sources, such as geothermal, hydroelectric power, solar, wind, and biomass, with a target share of 17 percent renewable energy. By 2025, the use of renewable energy can help reduce dependence on fossil fuels in the national energy supply system. Apart from that, global warming related to the consumption of fossil fuels is one reason to reduce the use of fossil fuels. Considering the role of renewable energy in the national energy supply system will be crucial in the future, policies are needed to support its sustainable implementation [1].

Future energy supply is a concern that affects all nations, as human welfare in modern life is closely tied to the quantity and quality of energy used. Access to energy is a crucial development factor for countries like Indonesia. With the development of the industry, economic growth, and population growth, energy demand has increased [2].

In connection with the development of the Horizontal Axis Wind Turbine (HAWT), extensive research has been conducted to produce a system that functions optimally. Where can the efficiency of this system be improved to obtain the maximum power factor? One of them uses multiple blades. This maximum power factor increases the Number of watts (power) produced, so that a smaller number of wind turbines is sufficient to produce a certain number of watts [3].

Non-renewable energy (fossil fuels) and renewable energy play a crucial role in human life. Many

community businesses are driven by energy, especially electricity. This is the government's primary task to provide electrical energy, which continues to increase over time. The amount of electricity installed in 2017 was approximately 60,789.98 MegaWatts (MW), representing a 1.9% increase from 2016, which was 59,656.30 MW [4].

Wind power manufacturers typically use either horizontal turbines or vertical wind turbines to harness power from wind flow. Generally, it consists of blades directed into the wind, connected to the rotor, and then to the generator. These systems require larger blades, taller towers, and more land area to achieve higher energy output. To capture more wind energy, manufacturers install rotors at the tops of tall towers because wind speeds near the ground are very low. However, complaints about threats to wildlife, noise and visual pollution, and high production and maintenance costs continue to hinder development [5].

Based on the background above, this research aims to test a Horizontal Axis Wind Turbine with a variation of three-bladed spiral blades, specifically regarding the effect of solidity number, to analyze whether a wind turbine with three blades can operate more optimally and effectively at certain wind speeds.

### 1.1 Wind Turbines

Wind turbines are windmills used to generate electricity. This wind turbine was initially developed to meet the needs of farmers for rice milling and irrigation. Many early windmills were built in Denmark, the Netherlands, and other European countries, and are commonly known as windmills. Now, wind turbines are increasingly used to meet people's electricity needs, based on the principle of energy conversion and utilizing renewable natural resources, specifically wind. Although wind turbine construction cannot be compared with traditional power plants (e.g.

PLTD, PLTU), researchers are still developing wind turbines, because in the near future, people will face the problem of a shortage of non-renewable natural resources (e.g., coal, petroleum) as raw materials for electricity production [6].

Wind turbines can be classified as energy converters based on the aerodynamic principles that affect the rotor. Based on aerodynamic principles, wind turbines are categorised into two types: drag-type and lift-type. The two aerodynamic principles used by wind turbines have different rotor rotations, where the drag principle has a relatively low rotor speed compared to wind turbines whose rotors use the lift principle. Based on the direction of the rotor's rotation axis, wind turbines can be divided into two categories: horizontal-axis wind turbines (HAWT) and vertical-axis wind turbines (VAWT) [7].

### 1.2 Types of Wind Turbines

The vertical-axis wind turbine was the first type of artificial wind turbine. Initially, rotor rotation utilised only the Magnus effect, which was caused by the difference in drag on both sides of the rotor or blade, thereby generating a torque about the rotor rotation axis. Main characteristics

Vertical axis windmills, or what is better known as the axis perpendicular to the direction of the wind flow, or perpendicular to the earth's surface [8]-[11].



Figure 1. Vertical axis wind turbine

A horizontal-axis wind turbine (HAWT) has a main rotor shaft and an electric generator at the top of the tower. Small turbines are controlled with simple wind vanes, while large turbines usually use wind sensors connected to servo motors. This type of wind turbine is the most common type of windmill used

today. This turbine consists of a tower topped with a propeller that functions as a rotor, either in the direction of the wind or veering away from it. Most of the wind turbines of this type produced today are equipped with two or three propellers [12].



**Figure 2.** Horizontal-axis wind turbine

A horizontal-axis wind turbine has a rotating axis parallel to the ground, and the rotor's rotating axis is in the direction of the wind. The main components of a horizontal-axis wind turbine consist of rotor blades, tail plane, tower, and generator. Based on the position of the rotor against the wind direction, horizontal axis wind turbines are divided into two types, namely: 1. Upwind, 2. Downwind

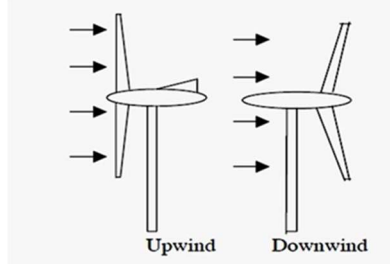

**Figure 3.** Upwind Turbin dan Downwind Turbin

**2. METHODOLOGY**

**2.1 Research Methods**

The field experimental trial aims to determine the actual power and torque produced by TASH by varying the blade shape to a spiral shape and the Number of blades to three under certain wind speed conditions. Before testing, a test tool was first made in the form of a spiral blade TASH prototype with three blade variations. The prototype was carried out in a series of trials in an open field on the edge of Tanjung Pasir beach, Tangerang Regency, Banten. Due to fluctuating wind speeds, the data collection process was carried out at 30-second intervals, and data collection was repeated 7 times. From the data obtained in the TASH trial, the average value was used to determine the actual wind speed, actual torque, and actual turbine power.

**2.2 Tools and Materials**

Tools and materials needed to support field test studies of horizontal-axis wind turbines with three spiral blades regarding solidity number effects.

**Table 1.** Tools and Materials

No	Tools and Materials	Allotment
1	Anemometer	Measuring wind speed.
2	Techometer	Measuring the Number of shaft revolutions.
3	Torque meter	Measuring the amount of torque of a rotating object.

4	Multimeter	Measuring the voltage and current output of the generator.
5	Generator	Converts rotational motion (mechanical) energy on the drive shaft into electrical energy.

Table 1 shows the tools and materials used in this research. The Anemometer was used for measuring the wind speed, while the tachometer was used for measuring the Number of shaft revolutions, and the Torque meter was used for measuring the amount of torque of a rotating object. The generator used here converts rotational motion (mechanical) energy on the drive shaft into electrical energy. A Multimeter was used for measuring the voltage and current output of the generator.

**2.3 Wind turbine design**

The following is a picture of the design of a three-bladed spiral horizontal-axis wind turbine used for field test experiments.

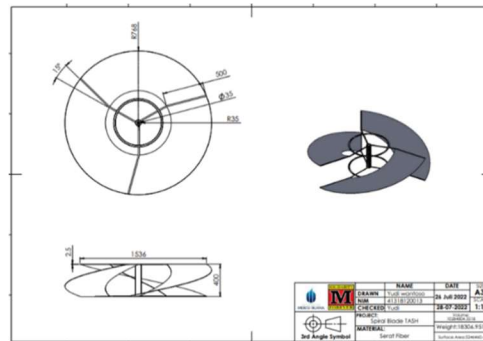

**Figure 4.** TASH Three spiral blades

**2.4 Experimental Study**

Actual power

Data collection occurs when the wind speed is stable. Variables obtained from test results include wind speed, rotation speed, voltage (V), and current (I). The equation obtains the actual (experimental) wind power value:

$$P_{exp} = V \times I \tag{1}$$

The theoretical power of the turbine is derived based on [13], so that the power coefficient Cp can be expressed as:

$$C_P = \frac{P_{w.exp}}{P_w} \tag{2}$$

And the theoretical power is derived from [10],

$$P_w = \frac{1}{2} \rho A V^3 \tag{3}$$

Calculation of torque value (Tth), obtained from [14], namely

$$T_{th} = \frac{1}{2} \rho A R H V_w^2 \tag{4}$$

And the torque coefficient value is determined from [15],

$$C_T = \frac{T_{exp}}{T_{th}} \tag{5}$$

Co-efficient speed (Tip Speed Ratio), TSR [16],

$$\lambda = \frac{C_p}{C_t} \tag{6}$$

Solidity Number is defined from [13],

$$\sigma = n^c/d \tag{7}$$

**Explanation :**

n = Number of blades/blades

c = Blade cord length

d = Outside diameter of the turbine

Measurable and unmeasurable parameters from turbine test results are calculated and analyzed using equations from 1 to 7.

**2.5 TASH prototype materials**

The TASH prototype material is made of fiber material with a thickness of 2.5 millimeters.

**Table 2.** Design parameters of spiral type TASH

Turbin	$L_r$ [mm]	$D_i$ [mm]	$D_o$ [mm]	$c$ [mm]	$\sigma_r$
3 blade	768	800	1536	500	0.976
4 blade	768	800	1536	500	1.302
5 blade	768	800	1536	500	1.627

**Explanation :**

$L_r$  : Rotor length

$D_i$  : Inner diameter

$D_o$  : Outer diameter

$c$  : Blade length

$\sigma_r$  : Solidity number

**2.6. Experimental procedures**

The process of collecting experimental data was conducted in an open area on the edge of Tanjung Pasir Beach, Tangerang Regency, Banten Province. Due to variations in wind speed, the data collection process was conducted at 30-second intervals, and data collection was repeated 7 times. From the HAWT experimental data, the average value is used to obtain the actual values of wind speed, torque, and turbine power.

**3. RESULT AND DISCUSSION**

**3.1 Tables and curves**

The following is a compilation of data from wind turbine test results used to calculate the parameters described above.

**Table 3.** Average Data Results of TASH field test data collection with three spiral blades

Interval	Time	Wind speed (m/s)	TASH Round (RPM)	Voltage (V)	Current (A)	Torque (N.m)
1	09:00	2.0	72.7	6.15	0.08	1.92
2	10:00	2.5	85.7	7.00	0.21	2.80
3	11:00	3	100.2	7.80	0.37	3.50
4	12:00	3.5	113.2	8.61	0.57	4.16
5	13:00	4	122	9.35	0.71	4.74
6	14:00	4.5	132	10.01	0.85	5.40

7	15:00	5	140	10.30	0.97	6.00
---	-------	---	-----	-------	------	------

**Table 4.** Data from analysis and calculations

Time	Wind speed (m/s)	Actual Power (Pexp) (Watt)	Theoretical Power (Pw) (Watt)	Coefficient Torque (Ct)	Coefficient Power (Cp)	Tip Speed Rasio (TSR)
09:00	2.0	0.492	7.411	0.674	0.066	0.098
10:00	2.5	1.470	14.476	0.629	0.101	0.161
11:00	3.0	2.886	25.015	0.546	0.114	0.211
12:00	3.5	4.907	39.723	0.477	0.123	0.258
13:00	4.0	6.638	59.295	0.416	0.112	0.268
14:00	4.5	8.508	84.426	0.374	0.100	0.268
15:00	5.0	9.991	115.811	0.337	0.086	0.255

**3.2 Analysis curve**

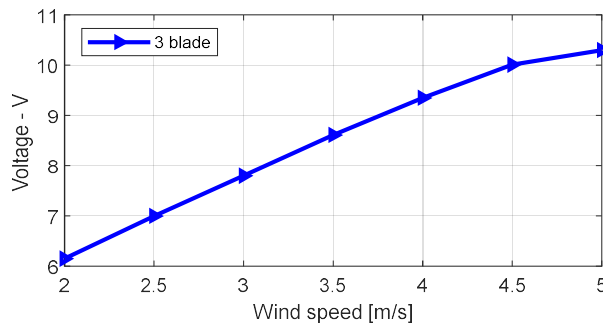

**Figure 5.** Curve of experimental results for voltage versus wind speed

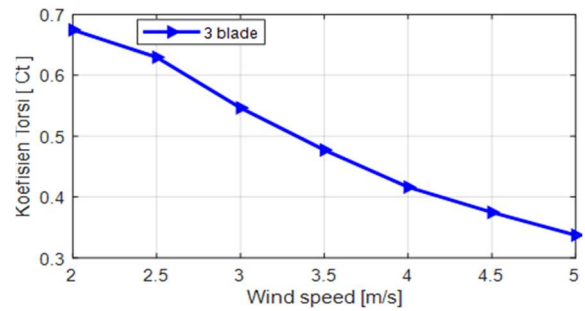

**Figure 9.** Torque coefficient curve against wind speed

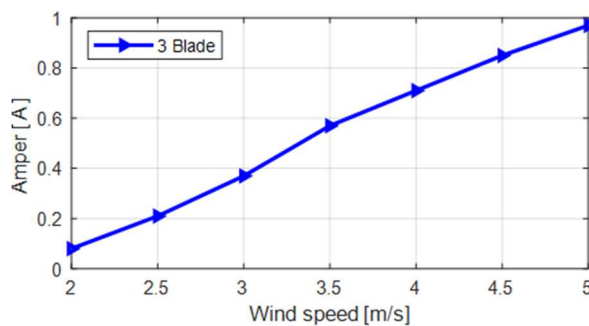

**Figure 6.** Curve of experimental results for current strength versus wind speed

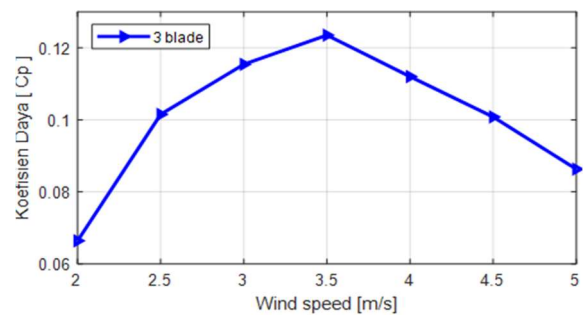

**Figure 10.** Power coefficient curve against wind speed

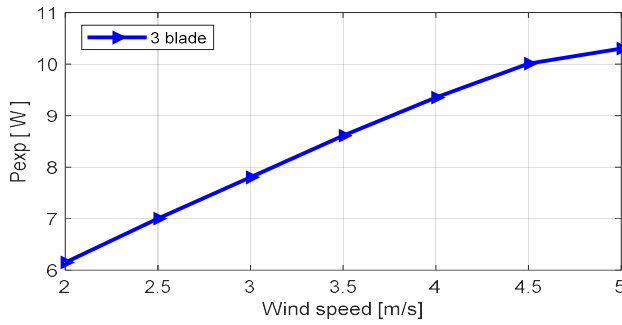

Figure 7. Actual power curve against wind speed

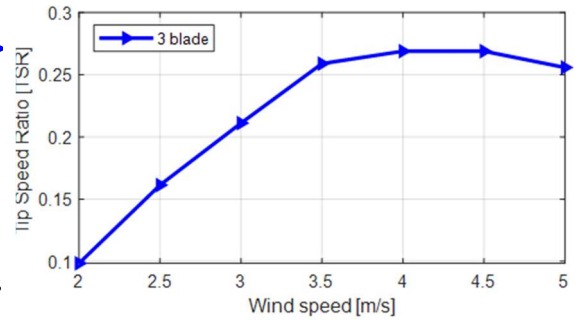

Figure 11. Tip Speed Curve Ratio to wind speed

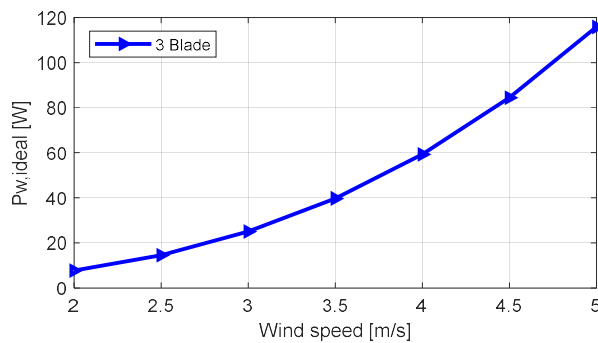

Figure 8. Wind power curve (Pw, ideal) against wind speed

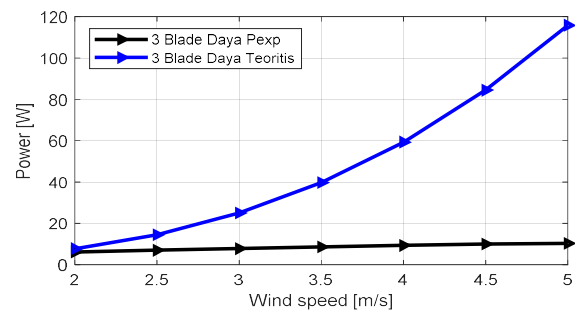
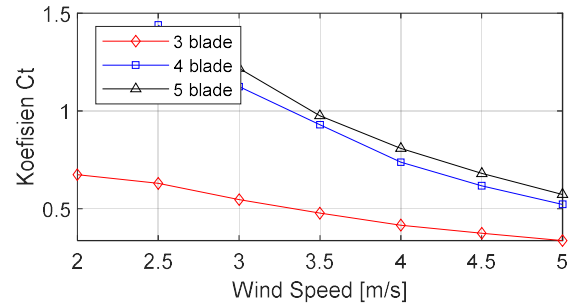
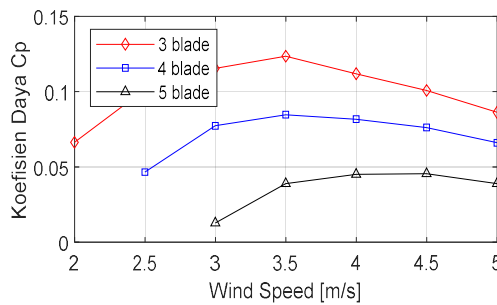

Figure 12. Theoretical and actual power curves against wind speed

### 3.3 Effect of Solidity Number

Influence of Solidity Number on the Performance of Horizontal Axis Wind Turbines.



Figures 13 & 14 . Power and torque coefficient curves against wind speed

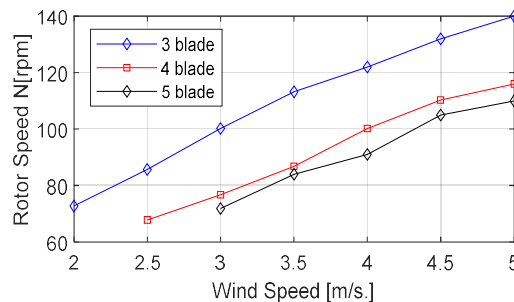

Figure 15. Rotor speed curve against wind speed

From the graphs in Figures 13 and 14 above, it can be observed that there is an increase in the power coefficient, coinciding with an increase in the turbine solidity number. This is because there is a decrease

in the rotor rotation speed, as shown in Figure 15, along with an increase in the turbine solidity number, due to the influence of increasing the Number of blades.

#### 4. CONCLUSION

From the discussion and analysis carried out based on the potential wind speed during testing, it can be concluded as follows:

1. From the analysis results, the smallest voltage and current generated are 6.15 V and 0.08 A at a turbine rotation speed of 62.4 r.p.m. with a wind speed of 2.0 m/s, and the highest voltage produced was 10.30 V and 0.97 A, namely at a turbine rotation speed of 140 r.p.m. with a wind speed of 5.0 m/s. The higher the wind speed, the higher the turbine rotation speed.
2. For the actual experimental power and theoretical power, the maximum values at a wind speed of 5.0 m/s are 9,991 watts and 17,788 watts, while the lowest values are 0.492 watts and 7.411 watts at a wind speed of 2.0 m/s. The maximum torque coefficient value is 0.6746 with a wind speed of 2.0 m/s. The maximum power coefficient is 0.0863 with a wind speed of 5.0 m/s, and the maximum value for the tip speed ratio (TSR) is 0.255 at a wind speed of 5.0 m/s.

#### REFERENCES

- [1] I. K. Wiratama, M. Mara, and L. E. Furqan Prina, "Pengaruh Jumlah Blade Dan Variasi Panjang Cord Terhadap Performansi Turbin Angin Sumbu Horizontal (Tash)," *Din. Tek. Mesin*, vol. 4, no. 2, p.p. 110–116, 2014, doi: 10.29303/d.v4i2.60.
- [2] P. S, S. S, and Taufik, "Keluaran Turbin Angin Tipe Horizontal Berdiameter 1 , 6 Meter Sebagai Sumber Penyedia Listrik Pada Proyek Rumah DC Di FMIPA Uni," *Semin. Nas. Fis. 2012*, pp. 89–94, 2012.
- [3] F. Aryanto, M. Mara, and M. Nuarsa, "Pengaruh Kecepatan Angin Dan Variasi Jumlah Sudu Terhadap Unjuk Kerja Turbin Angin Poros Horizontal," *Din. Tek. Mesin*, vol. 3, no. 1, pp. 50–59, 2013, doi: 10.29303/d.v3i1.88.
- [4] A. W. Biantoro, I. Iskandar, S. Subekti, and N. H. Bin Muhd. Noor, "The Effects of Water Debit and Number of Blades on the Power Generated of Prototype Turbines Propeller as Renewable Electricity," *J. Rekayasa Mesin*, vol. 12, no. 1, p. 203, 2021, doi: 10.21776/ub.jrm.2021.012.01.22.
- [5] A. F. Sudarma, M. Kholil, S. Subekti, and I. Almahdy, "The effect of blade number on small horizontal axis wind turbine (HAWT) Performance: An experimental and numerical study," *Int. J. Environ. Sci. Dev.*, vol. 11, no. 12, pp. 555–560, 2020, doi: 10.18178/ijesd.2020.11.12.1307.
- [6] Maiti and Bidinger, "Definisi Turbin Angin," *J. Chem. Inf. Model.*, vol. 53, no. 9, pp. 1689–1699, 1981.
- [7] V. Ansari and E. Prianto, "Prosiding SNST ke-5 Tahun 2014 Fakultas Teknik Universitas Wahid Hasyim Semarang 1," *Kaji Eksperimen Turbin Angin Poros Horiz. Tipe Kerucut Terpancung Dengan Variasi Sudut Sudu Untuk Pembangkit List. Tenaga Angin*, vol. 2014, no. Pp 101, pp. 1–6, 2021.
- [8] R. Syahyuniar, "Rancang Bangun Pembuatan Turbin Angin Type Horizontal Berdiameter 2,8 Meter Dan Output Daya Listrik 1000 Watt," *Elem. J. Tek. Mesin*, vol. 3, no. 1, p. 30, 2016, doi: 10.34128/je.v3i1.13.
- [9] Andriansyah, F., Indah, N., & Subekti, S. (2024). Harvesting energy vibration derived from the rotational speed of a A 4-stroke engine. *JTTM: Jurnal Terapan Teknik Mesin*, 5(1), 67-74.
- [10] Syahputra, M. N. A. F., Subekti, S., & Indah, N. (2024). Effect of eccentric mass on rotor dynamics as a source of harvesting energy vibration. *JTTM: Jurnal Terapan Teknik Mesin*, 5(1), 54-61.
- [11] Djanali, V. S. (2024). Identification of Nonlinear System for Elastically Supported Cylinder on Cross-Flow Using Wavelet Transform. *Jordan Journal of Mechanical and Industrial Engineering*, 18(1), 89-97.
- [12] Ismail and T. Arrahman, "Perancangan Turbin Angin Sumbu Horizontal Tiga Sudu Dengan Kapasitas 3 MW," *Presisi*, vol. 6, no. 3, p. 113, 2017.
- [13] J. Krishnaraj, S. Ellappan, and M. A. Kumar, "Additive Manufacturing of a Gorlov Helical Type Vertical Axis Wind Turbine," *Int. J. Eng. Adv. Technol.*, vol. 9, no. 2, pp. 2639–2644, 2019, doi: 10.35940/ijeat.b4116.129219.
- [14] D. H. Didane, N. Rosly, M. F. Zulkafli, and S. S. Shamsudin, "Performance evaluation of a novel

- 
- vertical axis wind turbine with coaxial contra-rotating concept," *Renew. Energy*, vol. 115, no. 2018, pp. 353–361, 2018, doi: 10.1016/j.renene.2017.08.070.
- [15] E. Tonadi, "Pengaruh Sudu dan Kecepatan Angin Terhadap Koefisien Torsi dan Koefisien Daya Serta Efisiensi Turbin Angin Savonius Sumbu Vertikal," vol. 15, no. 1, pp. 41–45, 2021.
- [16] R. Kumar and P. Baredar, "Solidity Study and its Effects on the Performance of A Small Scale Horizontal Axis Wind Turbine," *Impending Power Demand Innov. Energy Paths*, vol. 84, no. 8, pp. 290–297, 2015.