

PROPOSE SAFETY ENGINEERING CONCEPT SPEED LIMITER AND FATIGUE CONTROL USING SLIFA FOR TRUCK AND BUS

Hadi Pranoto^{1*}, Andi Adriansyah¹, Dafit Feriyanto¹, Abdi Wahab², Supaat Zakaria³

¹Faculty of Mechanical Engineering, Universitas Mercu Buana

²Faculty of Computer Science, University Mercu Buana Jakarta, Indonesia
Jalan Raya Meruya Selatan, Jakarta 11650, Indonesia

³Department of Mechanical Engineering, Politeknik Ungku Omar
Jalan Raja Musa Mahadi, 31400 Ipoh, Perak, Malaysia

*Corresponding Author Email: hadipranoto@mercubuana.ac.id

Abstract -- In 2015, there were 55 deaths from 6,231 accident cases that occurred in Jakarta. A severe problem in Indonesia is the absence of a unique safety device in both commercial transport or personal vehicles and the very high complexity problem of human highways. Consequently, there are many traffic accidents caused by the negligence of the driver, such as driving a vehicle in a drunken, tired, drowsy, or over-limit speed. Therefore, it needs to be innovative using devices to increase speed but able to detect the level of tired or sleepy drivers. This paper tries to propose a concept of improving safety engineering by developing devices that can control the speed and level of safety of trucks and buses, named SLIFA. The proposed device captures the driver's condition by looking at the eyes, size of mouth evaporating, and heart rate conditions. These condition will be measured with a particular scale to determine the fatigue level of the driver. Some performance tests have been carried out on truck and bus with 122 Nm and 112 Nm torque wheels and 339 HP and 329 HP power values, respectively, and the minimum speed is 62 km/h. At a top speed of 70 km / h, the torque and power of the truck are 135Nm and 370HP, with average fuel consumption of 3.43 liters/km before SLIFA installation and average fuel consumption of 4.2 liters/km after SLIFA installation. SLIFA can be said to have functional eligibility and can cut fuel consumption by 81 percent.

Keywords: Accident; Fatalities; Safety Engineering; Recognition; Fatigue

Copyright © 2020 Universitas Mercu Buana. All right reserved.

Received: March 12, 2020

Revised: April 23, 2020

Accepted: May 1, 2020

Published: July 15, 2020

INTRODUCTION

In 2015, there were 556 fatalities from 6,231 accident cases that occurred in Jakarta [1]. It may cause by drivers reckless or excess speed while driving, fatigue, and several other cases related to attitude. Enforcement by the traffic police continues to be an essential step that must be carried on against violators of speed to ensure the safety of traffic to the community [2, 3, 4]. The results revealed five human factors that significantly increase the risk of causing an RTA. These factors are according to the strength of their impact: (1) inappropriate speed, (2) fatigue, (3) unintended blindness, (4) annual mileage between 20,000 and 40,000 km, and (5) having a conversation with the passenger.

According to the system approach, the occurrence of RTAs can cause by numerous contributing factors, namely the human, the vehicle, and the road environment [5, 6, 7]. The factors that caused the road traffic accident consists of vehicle, environment, and the human factor, which shown in Figure 1. Ideally, each

layer should be intact. If one of these layers is not intact (has a hole), an RTA is likely to occur.

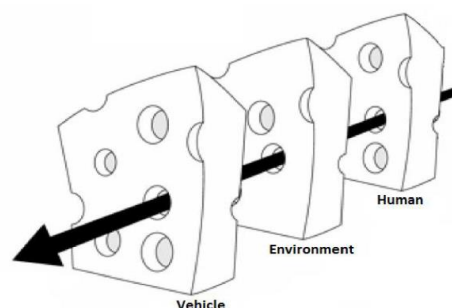

Figure 1. Reason swiss cheese model adapted to the three factors [8]

Since human factor contributes to 90 % of all RTAs, it can conclude that revoking the driver licenses from accident-prone drivers would be an adequate measure to improve road safety. This step would be in line with an approach known as the personal approach or the accident-prone individual approach [9].

Traffic accidents often cause by three different factors, namely, human factors, vehicle factors, and external factors that include road conditions Figure 2. Human factors have the most substantial influence, as figures from around the world suggest. The focus of this study, however, is on non-human factors in Indonesia since weak growth of road infrastructure (a reduced road ratio), poor public transportation, and the adverse phenomena of motorbike ownership and use have often been discussed. The road network infrastructure in Indonesia has experienced slow growth for many years, and some cities have demonstrated poor road network maintenance.

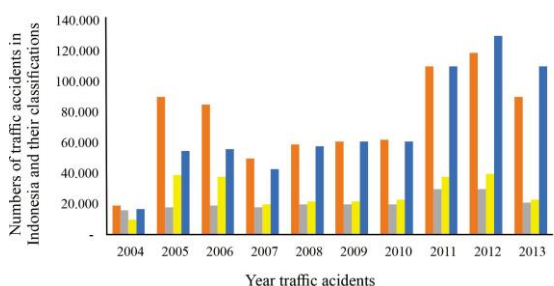

Figure 2. Traffic Accident In Indonesia [10]

Correlation between over speeding and accident

Contribute to future studies about safety climate and safety outcomes in the trucking industry. Similar statistics have to report for the United States of America (USA), where approximately 63,000 buses are involved in traffic crashes each year, resulting in a total of 325 fatalities, 0.8% of total road fatalities [9]. A meta-analysis was build to determine the overall effect of speed reductions on the number and severity of injuries to road users. For the meta-analysis, researchers identified a total of 174 speed-related studies. Of those, 97 contained enough information to be included in the assessment, which consisted of 460 estimations of the benefits associated with reduced speed. When the meta-analysis results were conducted, researchers noticed a slight deviation from the proposed equation.

However, the findings came within reasonable expectations of the initially recommended exponent values, and the model was revised so that the incident types were counted as mutually exclusive events. Table 1. displays the revised exponent values. The study concluded that the strong linear relationship between speed and road safety might be causal. Indicates if the vehicle speed to reduce, there will also be a decrease in the number of crashes and injuries.

Table 1. Assessment of injury severity relative to the speed [11]

Incident Type	Revised Exponent	95% Confidence Interval
Injury Severity:		
Fatalities	4.5	4.1-49
Seriously Injured Road User	2.4	1.6-3.2
Slightly Injured Road User	1.5	1.0-20
All Injured Road User (including Fatalities)	1.9	1.0-28
Accident Severity:		
Fatal Accidents	3.6	2.4-4.8
Serious Injury Accidents	2.0	0.7-3.3
Slightly Injury Accidents	1.1	0.0-2.4
All Injury Accidents (including Fatal)	1.5	0.8-22
Property-Damage-only Accidents	1.0	0.0-20

Correlation between fatigue detection and accident

Some related news and research on accidents related to fatigue among drivers have found that fatigued significantly increases the risk of a crash. It makes us less aware of what is happening on the road and impairs our ability to respond quickly and safely if a dangerous situation arises. Fatigue driver believed to contribute to more than 30% of road crashes. Bus driver inattention/fatigue was considered to be the primary cause of road crashes [9]. Drowsiness is a condition where a person feels like sleeping. It can happen at the wrong time, for example, when working, while studying, or when driving, as shown in Figure 3 Sleepiness is usually characterized by fatigue, loss of consciousness, sleep and can interfere with activity. Drowsiness generally occurs due to a lack of sleep.



Figure 3. Drowsiness

Everyone has different sleeping needs, depending on age and daily activities. Ideally, adults need seven to nine hours of sleep per day, children up to teenagers need nine hours, toddlers take ten to twelve hours, and newborns take 16-18 hours [2].

Although it looks simple, drowsiness can lead to problems, such as interrupting performance and productivity at school, college, or office, affecting one's emotions, interfering with social interactions, and the most fatal is that it can cause accidents both on the road and in the workplace [12].

METHOD

The preliminary design has consisted of calculation, concept verification, parameter determination, and specification of datasheet component. Figure 4 shows the proposed new features design system. The GPS provides input to the new features as a trigger to determine the position of the vehicle when it is on the highway, non-highway, and pedestrian road.

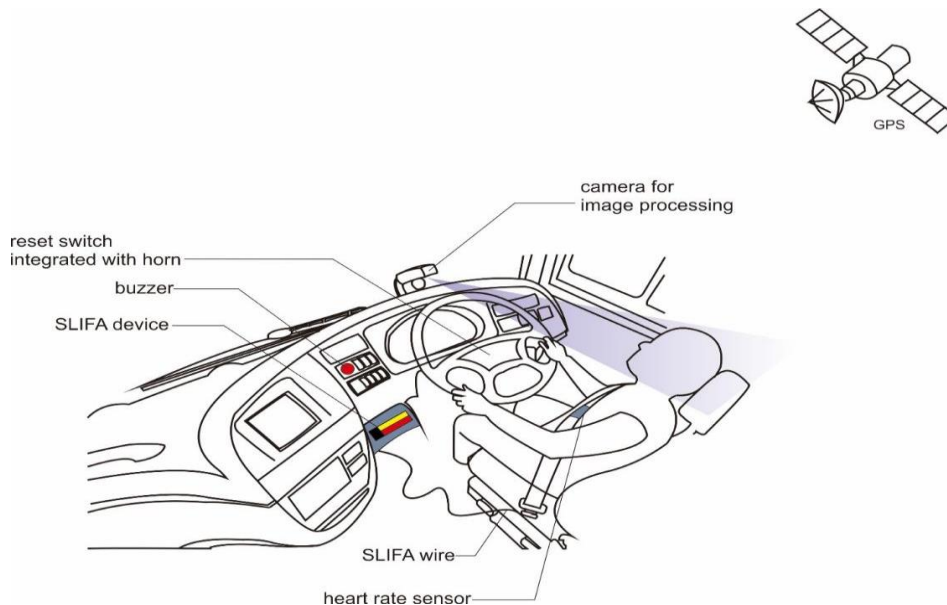

Figure 4. Overview concept design of new features system

GPS also gives instruction and information to the new features for limiting the speed according to government regulation. Image processing with camera and heart rate acted as the input fatigue detection on the driver. When fatigue detected, new features provided a warning via an alarm. If the driver does not respond to the signal by resetting it using the horn as a reset switch, the new features will reduce vehicle speed up to a maximum of 30 km/h. This test ensured the accuracy frequency value was converted in voltage Table 2. This value was used as a parameter for adjusting the speed limit and decreased vehicle speed if the fatigued driver was detected.

Fatigue calibration conducted by mapping 68 facial points to obtain a specific face for the facial detector. These 68 mapping points were used to describe driver condition from their face [13]. Mouth and eye conditions were used as the main parameter to determine fatigue, which occurred, as shown in Figure 5.

Table 2. Speed Calibration test

Calibration Speed to Voltage			
No.	Speed (km/h)	No.	Voltage (volt)
1	0	1	0
2	10	2	1.2
3	20	3	1.8
4	30	4	3.6
5	40	5	5.3
6	50	6	7.1
7	60	7	8.9
8	70	8	10.7



Figure 5. Drowsiness driver noticed from image processing SLIFA device

Mouth and eye condition data obtained from facial detectors were stated as the ES and MS value. These values were converted into a 1-9 SSS scale after integrated it with the driver's heart rate value and body temperature. The SS value is as stated in Figure 6 [14].

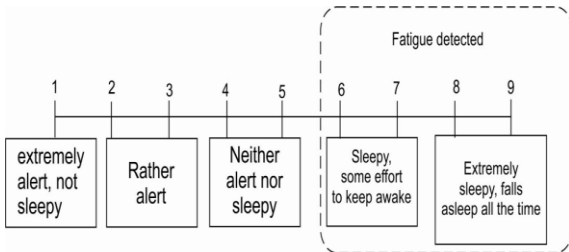

Figure 6. SLIFA sleepiness scale adapted from the Karolinska sleepiness scale.

Fatigue driver detection was conducted using a sleepiness scale as the main input parameter. Several parameters measured the sleepiness scale. The parameters are the driver's heart rate, the Mouth Aspect Ratio (MAR), the Eye Aspect Ratio (EAR), and the body temperature. These items are measured using the temperature sensor and real-time image processing. All parameters will be converted to a scale adapted from the Karolinska Sleepiness Scale [15]. The facial landmark detector implemented in the digital library module produced 68 coordinates (x,y)-capable of mapping specific facial structures [13]. If the driver detected a fatigue condition, the vehicle speed would be reduced to 30 km/h.

The face area is accessible through simple python indexing, assuming zero indexing with python because the image above is one-index. Access coordinates on each face region are described as follows [13]:

1. The mouth is accessible via point.
2. Right eyebrows pass the point.
3. Left eyebrows pass the point.
4. The right eye uses.
5. The left eye width

Installation Procedure on the Diesel Engine

SLIFA installation procedure, as shown in the schematic circuit Figure 7, was performed using the following steps:

1. For diesel trucks and buses, the device was connected to the cable on-brakes of the fuel system as once installed, the existing engine stopped the original motor.
2. After the first point had been made, the point is connected with a cable to the box SLIFA to the process in an electronic circuit. Then the results are forwarded to the speed sensor on the transmission output.
3. The data pulse from the speed sensor was sent to the speed sensor back and connected to the motor engine stop relay.
4. After the SLIFA is attached to the dashboard bracket, then the cable is connected with several sensors including a camera for recognition on the dashboard, a sensors heart rate in a safety belt, and then GPS sensor which is placed above the panel so that the signal from the satellite is easy to connect.

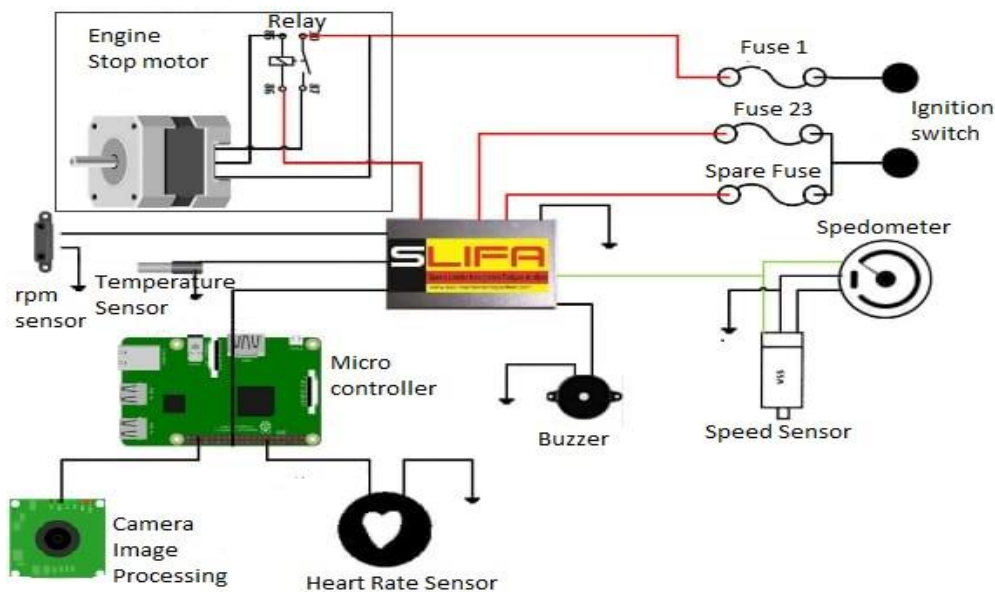

Figure 7. Circuit installation procedure on the diesel engine truck and bus.

RESULTS AND DISCUSSION

Installation of SLIFA on Truck and bus

A trial session was conducted to find out the length of success of the SLIFA development applied in the truck and bus. Before SLIFA used in a real vehicle, SLIFA was tested in diesel engine stand test bench, and this step was needed to minimize the potential failure in the SLIFA device.

After trial success, the next level, the installation procedure of SLIFA to the vehicle, is shown in Figure 8. Generally, there were three wire from the car that needed to be connected entirely with the SLIFA device, which is the signal wire from engine speed, fuel cut off solenoid wire, and ECU wire.



Figure 8. Selected bus with ID No. OH-1526 [16]

The working principle of the SLIFA when the vehicle speed exceeds a specified speed limit was as the following. Speed limiting system uses two main inputs based on speed sensor and feedback based on GPS location, which will send a signal through the Raspberry Pi to be able to send frequency to the fuel cut of the relay. First, the speed sensor at the transmission output sent the frequency signal to the accelerator pedal and then if based on GPS location. Then the frequency signal was transformed into a voltage signal at the IC program. The voltage signal was later transformed into the comparators components, forwarded to relay and followed by sound a warning alarm buzzer. When the driver still performed additional speed, the fuel shutoff solenoid reduced the fuel consumption into the engine. It automatically reduced the speed/RPM to the average rate (below max. speed). Meanwhile, when the driver decreased the speed, the buzzer alarm stopped and backed to the average speed. The truck and bus completed with the location of SLIFA used in this study are as shown in Figures 6 and 7, respectively.

Effects of SLIFA on Engine Performance and Fuel Consumption

Engine Performance Effect

The installation of SLIFA on trucks and buses engine was expected to bring effects to the

engine performance and fuel consumption of the truck and bus installed with the device. The efficiency of fuel consumption of SLIFA on both vehicles was analyzed since the results were related to engine performance. Engine performance and fuel consumption analyses were conducted using a four-stroke diesel engine six cycles and were explained by the dynamometer dyno dynamics. The studies were conducted in a lab-scale on the truck and bus with a serial number of SG-500 and OH-1526, respectively.



Figure 9. Testing SLIFA on dyno test dynamic

Dynamometer dyno dynamics conducted engine performance analysis. This test purpose was to investigate the effect of SLIFA on engine performance regarding the P-max, V-const, Power curve, Speed check, F-Const. Engine performance analysis was conducted using the dynamometer dyno dynamics. The study measured the torque and power at a different speed, such as 62km/h to 70km/h on the diesel engine of trucks and buses.

The performance test was repeated three times using a dyno test with different speed and engine rotation to describe the real condition. Figure 9 shows the engine performance before and after SLIFA implementation. The engine performance test, the torque wheel, and power value of Truck SG 500 for 122Nm and 339HP and Bus OH-1526 for 112Nm and 329HP, respectively, with a minimum speed of 62 km/h. At the highest rate of 70 km/h, Truck SG 500 showed torque and power of 135Nm and 370HP and Bus OH-1526 of 135Nm and 370HP, respectively. Meanwhile, after SLIFA installation, the performance of the truck increased to 420 Nm, and 148 HP and the bus increased to 420 Nm and 128 HP.

The highest achievement of truck and buses were located at a speed of 66 km/h with a load of 30 N. The analysis showed that SLIFA

installation in truck and bus able to improve the engine performance. It has been seen that when the torque reaches the highest value, it

consumes more fuel. The condition is illustrated in Figure 10.

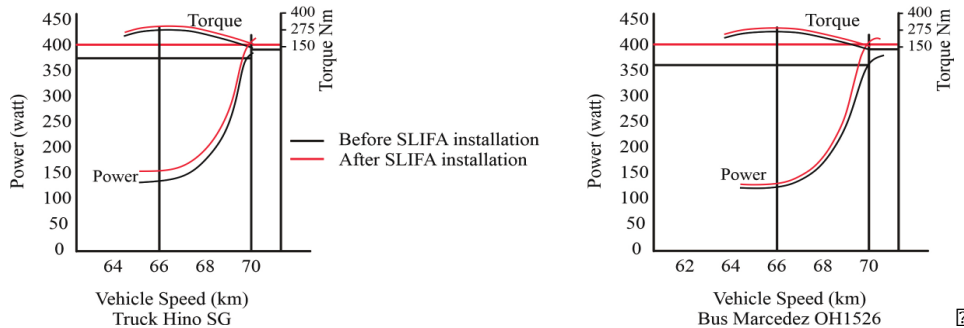

Figure 10. Engine performance test before and after installation SLIFA

Fuel Consumption Effect

Fuel consumption analysis on diesel truck and bus engine before SLIFA implementation were conducted to obtain the preliminary data of fuel consumption, which were acquired through the digital fuel test meter. Fuel consumption analysis was performed on a truck in the working area of route A: Jakarta-Cikampek highway, route B: Tam Krawang to Tam Cibitung highway, route C: Tam Cibitung to Tam Krawang highway and road D: Tam Karawang to Bandung highway. The total distance of this analysis was 143 km,

with a total load of 31,620 kg. The fuel consumption test showed that the fuel consumption ratio was 1:2.3 l/km. The results of the fuel consumption rate before speed limiter implementation were as described in Table 3 and Figure 11, with the average fuel consumption at 1:3.43l/km. The result shows that the distance decreased together with the fuel consumption as well. The highest fuel consumption is indicated by route D, which was 22.941 liters with a length of 74.8 km.

Table 3. Total fuel consumption before the SLIFA installation

Weight of vehicle + body (kg)	Route	Total Used Fuel Consumption			Fuel Consumption value (liter)	Fuel Consumption Ratio (l/km)
		Total Distance (km)				
		Start	Finish	Distance		
20,940	A	118,730	118,778	59.9	14.873	1:4.03
31,629	B	118,778	118,823	34.6	11.802	1:2.93
20,940	C	118,823	118,856	33.6	9.651	1:3.48
30,720	D	118,856	118,931	74.8	22.941	1:3.26

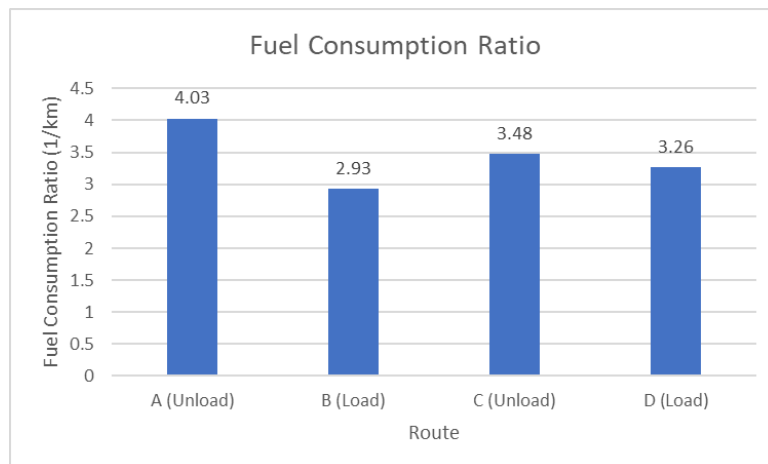

Figure 11. Fuel usage before installation SLIFA

The analysis of fuel consumption that performed in SLIFA was found to be effective in reducing fuel consumption as compared with before SLIFA was installed. It was also found that. The top speed of the truck is 133 km/h before the installation of the speed limiter. Meanwhile, when the speed limiter was installed to the truck, the top speed was limited at 70 km/h. The condition means that the cut-off fuel system was very useful to limit the speed at 70 km/h. Before the installation of speed limiters on

the bus, the highest and average speed was observed at 136 km/h and 123.5 km/h, respectively. After speed limiters, the maximum speed for the bus was 70 km/h. The average fuel consumption was 1:3.43 l/km, and fuel ration after SLIFA installation was 1: 4.2 l/km.

The installation of SLIFA had improved fuel consumption by decreasing it by 81%. The result of fuel consumption analysis after SLIFA applied is as shown in Table 4, while Figure 12 shows fuel usage after SLIFA installation.

Table 4. The total used fuel consumption after the installation of SLIFA

Weight of vehicle + body (kg)	Route	Total Used Fuel Consumption			Fuel Consumption value (liter)	Fuel Consumption Ratio (l/km)
		Total Distance (km)				
		Start	Finish	Distance		
20,940	A	118,730	118,778	59.9	12,873	1:4.65
31,629	B	118,778	118,823	34.6	9,802	1:3.47
20,940	C	118,823	118,856	33.6	7,651	1:4.39
30,720	D	118,856	118,931	74.8	20,941	1:3.57

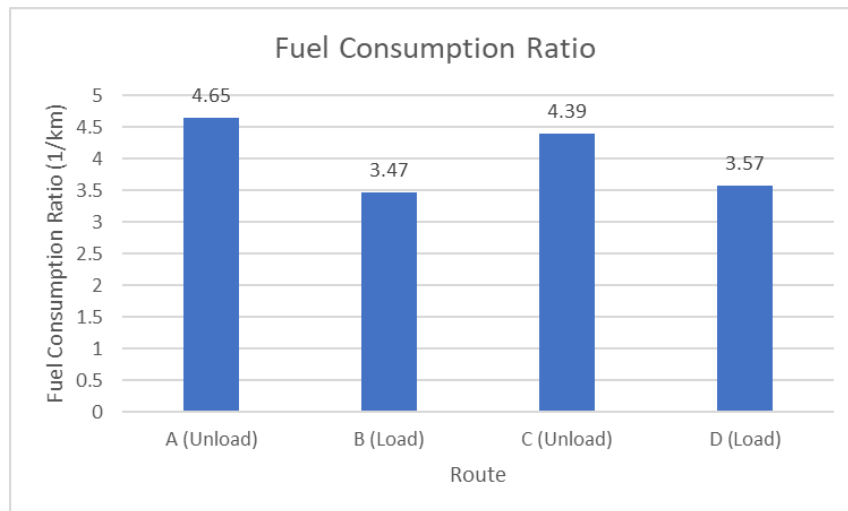

Figure 12. Fuel usage after installation SLIFA

The trial was needed to make sure that the SLIFA works accordingly. Excellent performance the engine and right economical fuel were used to assist the feasibility of SLIFA devices when the 2performance is done, SLIFA triggers the achievement of the maximum torque, and the fuel consumption can be more economical.

CONCLUSION

The SLIFA development process consisted of programming the SLIFA devices, developing of the SLIFA server, developing of the SLIFA client, and integrating the process between the tools and the application. SLIFA had been prepared well by using the Raspberry Pi, which was integrated with heart rate sensor, temperature sensor, GPS whose function is to make the speed limiter trigger automatically when on the

toll road, and road preservation, by the speed limit regulations set by the Indonesia government, and GSM module that serves to provide a signal that can be connected to the system. The SLIFA be equipped with a memory card and camera that can be used for image acquisition of fatigue detection. The SLIFA was connected with a vehicle speed sensor and relay engine cut off as the speed limiter. Before the SLIFA was installed in a real vehicle, a trial was conducted on a diesel engine stand test bench. The trial was needed to make sure that the SLIFA works accordingly. Some analysis was done on SLIFA included engine performance and fuel consumption analysis was used to assist the feasibility of SLIFA. The result shows that SLIFA had useful usefulness.

ACKNOWLEDGMENT

This research was supported/partially supported by the Ministry of Research and Technology/ BRIN, University Mercu Buana Jakarta, and Industrial Partner PT Anugerah Sarana Dinamika. We thank our colleagues from Politeknik Ungku Omar, Malaysia. He provided insight and expertise that greatly assisted the research, although they may not agree with all of the interpretations/conclusions of this paper.

REFERENCES

- [1] H. Pranoto, A. M. Leman, I. Baba, D. Feriyanto, and G. W. Putra, "Improving Road Safety of Tank Truck in Indonesia by Speed Limiter Installation," in *MATEC Web of Conferences*, Sarawak, Malaysia, October 2017, vol. 87, pp. 02022. DOI: 10.1051/mateconf/20178702022
- [2] S. Ari Sandhyavetri, Zamri, Sugeng Wiyono, "Three Strategies Reducing Accident Rates at Black Spots and Black Sites Road in Riau Province, Indonesia," *Transportation Research Procedia*, vol. 25, pp. 2153–2166, 2017. DOI: 10.1016/j.trpro.2017.05.415
- [3] J. I. Castillo-Manzano et al., "From legislation to compliance: The power of traffic law enforcement for the case of study of Spain," *Transport Policy*, vol. 75, pp. 1-9, March 2019. DOI: 10.1016/j.tranpol.2018.12.009
- [4] O. F. Hamim et al., "A sociotechnical approach to accident analysis in a low-income setting: Using Accimaps to guide road safety recommendations in Bangladesh," *Safety Science*, vol. 124, pp. 104589, April 2020. DOI: 10.1016/j.ssci.2019.104589
- [5] H. Pranoto, A. M. Leman, F. Anggara, and M. Kholil, "Speed limiter integrated fatigue analyzer (SLIFA): engineering design and concept," *TELKOMNIKA*, vol. 17, no. 1, p. 508, 2019. DOI: 10.12928/telkomnika.v17i1.8249
- [6] A. Detho et al., "Road Traffic Accidents (RTAS) Safety Issues on Highways: A Review," *QUEST Research Journal of Science and Technology*, vol. 17, no. 01, pp. 34-40, Jan-June 2019.
- [7] S. Kumar et al., "Analysis of risk factors contributing to road traffic accidents in a tertiary care hospital. A hospital based cross-sectional study," *Chinese Journal of Traumatology*, vol. 23, no. 3, pp. 159-162, June 2020. DOI: 10.1016/j.cjtee.2020.04.005
- [8] S. Hwanga S. and Lee, "Wristband-type wearable health devices to measure construction workers' physical demands," *Automation Construction*, vol. 83, pp. 330–340, November 2017. DOI: 10.1016/j.autcon.2017.06.003
- [9] F. Hidayati, N., Liu, R., & Montgomery, "The Impact of School Safety Zone and Roadside Activities on Speed Behaviour: the Indonesian Case," *Procedia - Social and Behavioral Science*, vol. 54, pp. 1339–1349, October 2012. DOI: 10.1016/j.sbspro.2012.09.848
- [10] H. Wahyudi, H. Pranoto, A. M. Leman, D. Sebayang, and I. Baba, "Speed limiter integrated fatigue analyzer (SLIFA) for speed and fatigue control on diesel engine truck and bus," in *AIP Conference Proceedings*, 2017, vol. 1885, pp. 020205. DOI: 10.1063/1.5002399
- [11] M. Yahya, I. J. Faulks, P. Hambleton, and C. Wass, "Development of an integrated road safety management system in Indonesia: Traffic police as lead agents in a Safe System approach," *The Journal of the Australian College of Road Safety*, vol. 24, pp. 28-38, 2013.
- [12] A. T. and P. G. George Y., "Investigation of road accident severity per vehicle type," *Transportation Research Procedia*, vol. 25, pp. 2076–2083, 2017. DOI: 10.1016/j.trpro.05.401
- [13] S. Feng, Z. Li, Y. Ci, and G. Zhang, "Risk factors affecting fatal bus accident severity: Their impact on different types of bus drivers," *Accident Analysis & Prevention*, vol. 86, pp. 29–39, January 2016. DOI: 10.1016/j.aap.2015.09.025
- [14] A. Abegaz, T., Berhane, Y., Worku, A., Assrat, A., & Assefa, "Effects of excessive speeding and falling asleep while driving on crash injury severity in Ethiopia," *Accident Analysis & Prevention*, vol. 71, pp. 15-21, October 2014. DOI: 10.1016/j.aap.2014.05.003
- [15] Yassierli, M. Mahachandra, and I. Z. Sitalaksana, "Fatigue Evaluation of Fuel Truck Drivers," *Procedia Manufacturing*, vol. 4, pp. 352–358, 2015. DOI: 10.1016/j.promfg.2015.11.051
- [16] H. Pranoto, "Efisiensi Power Engine Truck Pergerakan Dinamis dengan Mengubah Ratio Final Gear pada Truck Kapasitas 30 Ton," *SINERGI*, vol. 19, no. 1, pp. 45-50, February 2015. DOI: 10.22441/sinerigi.2015.1.008